

COMFORTEDGE™ | SERIES 759 COMFORTEDGE™ SLIDING DOOR

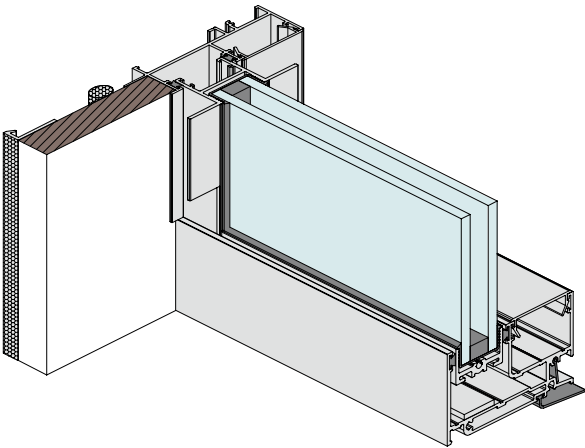

KEY FEATURES

- The Series 759 ComfortEDGE™ sliding door is a patented, energy efficient, sliding door system designed to have minimised sightline from the aluminium frame and panel.
- The top and bottom rails and jamb stiles are concealed in the perimeter frame to greatly improve thermal performance by reducing the amount of exposed frame.
- Concealed framing delivers a clean, minimalist, architectural look on both the inside and outside for a premium aesthetic.
- This double glazed system will accept 22mm and 24mm IGUs with a maximum panel weight of 320kg.
- Large sliding doors can be fabricated in high wind load areas and doors configurations can span up to 19m.
- Designed exclusively to accept Vantagard™ high performance security screens and BRIO pleated screens.

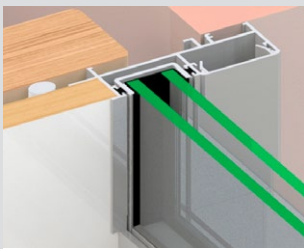

ComfortEDGE™ framing embedded into the building envelope delivers a clean, architectural finish, uninterrupted sightlines and outstanding thermal performance.

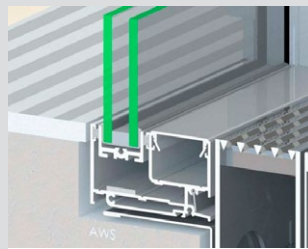

A custom stainless steel, flat running track combined with custom stainless steel rollers and track brushes, ensure optimal, long term operating performance.

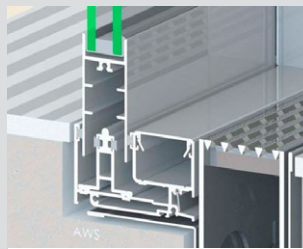

Optional heavy duty bottom rails and running track can be selected for high exposure areas and extra wide spans to improve overall strength to suit almost any application.

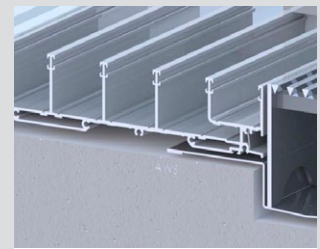

Up to 5 track sill configurations are available to suit extra wide openings up to 19m wide.

GENERAL

Max Frame Height*
3000mm

Max Panel Width*
2000mm

Max Glass Thickness
24mm

Frame Depth
84mm - 208mm

ENERGY

UW Range
1.6-5.9

SHGC Range
0.21-0.75

WEATHER

Maximum Water
400 Pa.

ACOUSTICS

This product has not been acoustics tested.



*Dimensions subject to individual site conditions. Frame Height and Panel Width are interdependent.