

RESIDENTIAL SERIES | SERIES 542
D'STACKER™ SLIDING DOOR

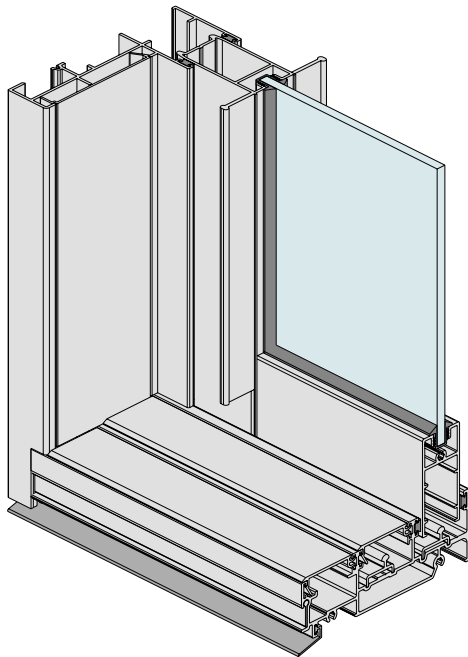

KEY FEATURES

- This door can be fabricated as a multi-panel stacker with a clean flat sill where all unwanted recesses are closed off with snap-on fillers. We have a stacking screen door system to go with the glass doors.
- The 109mm wide perimeter frame will couple to a large variety of Vantage adaptors.
- Flat external fillers create a clean closed off frame appearance. On the sill the infills guide water away from the door panels and improve water resistance.
- A large variety of locks are available.
- Heavy door panels can be fitted with double or quad bogey wheels for smooth long-term operation. Running rails can be replaced in the future if necessary.
- Compatible flyscreen system with:
 - Heavy duty spring loaded wheels top and bottom.
 - Snap-fit trailing style interlocker.
 - Matching hardware.
- This door has been acoustically tested.

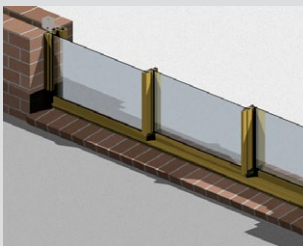

Series 542 D'Stacker™ is designed to be configured as multi-stacking doors up to 3 panels in each direction. Ideal for creating wide residential openings.

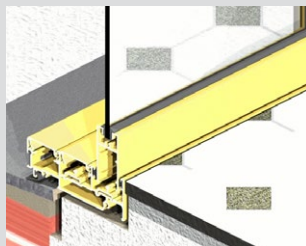

Semi and fully recessed sill options available to create seamless transition between internal and external. Semi recessed sill pictured above. Drains must be used with all fully recessed sill installations.

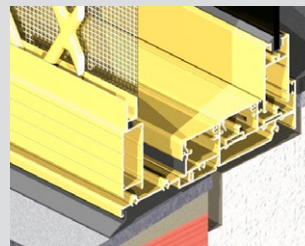

Integrated flyscreen sill for multi-stacking applications.

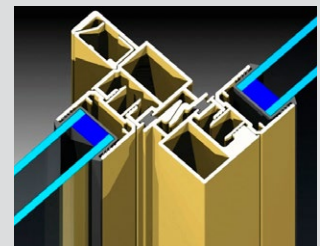

Will accept glass up to 20mm – shown above with adaptors to accept wide IGUs.

GENERAL

Max Frame Height*
2700mm

Max Panel Width*
1350mm

Max Glass Thickness
20mm

Frame Depth
108.6mm

ENERGY

UW Range
2.7-6.2

SHGC Range
0.22-0.72

WEATHER

Maximum Water
300 Pa. Sump Sill

450 Pa. Sump Sill in sub-sill

ACOUSTICS

6mm Float + Rail Stiffeners
Rw 31

10mm Float + Rail Stiffeners
Rw 33

20.38mm**
Rw 33

20.38mm + Rail Stiffeners**
Rw 34



*Dimensions subject to individual site conditions. ** IGU 6mm Glass/8mm Air/6.38mm Lam
 BAL-40 compliance may limit glass options. Maximum glass size for BAL-40 products is 5m².
vantagealuminium.com.au/542