

COMMERCIAL SERIES | SERIES 665
AWNING WINDOW (150mm)

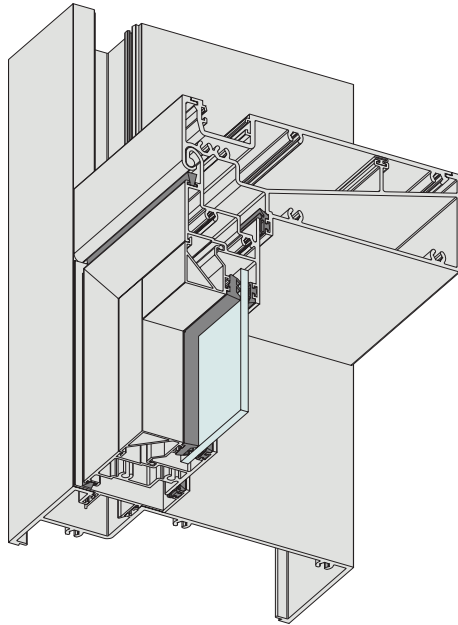

KEY FEATURES

- Custom Elevate™ framing has been used to create this high-performance commercial awning window suitable for use in high wind load applications.
- Series 665 sashes are fabricated as a hook hinge design, single or double glazed.
- The strong sashes allow large opening sash windows to be fabricated for high wind load areas. Large single sash awning windows have been successfully tested to resist up to 8000Pa Ultimate negative wind load using custom AWS Performance Side Latches. AWS have also successfully tested the sashes to resist 600Pa water externally or internally beaded and is suitable for air-conditioned buildings.
- When glazed internally we use square glazing beads. On the externally glazed sash, the standard bead configuration is still square beads. We also offer splayed beads. Splayed and square can be mixed (square verticals and splayed horizontals).
- Electric chainwinders are available as an alternative to single or twin manual chain winders.

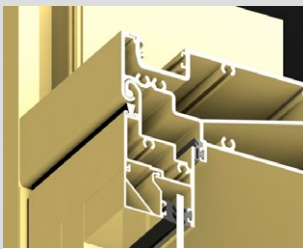

Series 665 sashes are fabricated as a hook hinge design, single or double glazed.

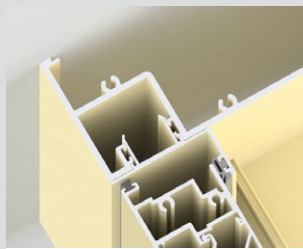

Awning sash stops compatible with series 600, 602, 622 and 626 commercial framing

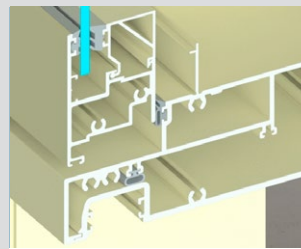

Can be externally or internally glazed. Square beads are used as standard on internally beaded sashes.

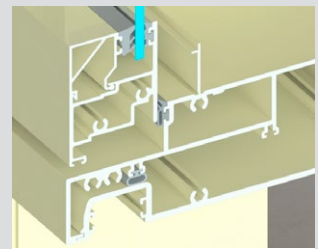

On externally beaded sashes the standard bead configuration is square however splayed beads are available.

GENERAL

Max Panel Height*
 Various

Max Panel Width*
 Various

Max Glass Thickness
 24mm

Frame Depth
 150mm

ENERGY

UW Range
 4.6-5.3

SHGC Range
 0.17-0.48

WEATHER

Maximum water
 600 Pa.

ACOUSTICS

N/A



*Dimensions subject to individual site conditions.