

DESIGNER SERIES ThermalHEART® | SERIES 731
THERMALLY BROKEN SLIDING DOOR

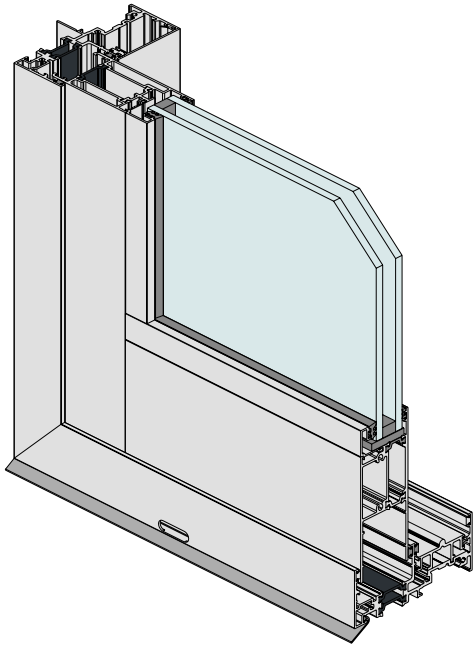

KEY FEATURES

- Series 731 incorporates ThermalHEART® technology giving a true wide thermal break between the outside and inside faces. ThermalHEART® systems perform up to 32% better than traditional aluminium windows and doors.
- ThermalHEART® will accept insulating glass units up to 37.5mm thick. The typical IGU thickness is 24mm.
- The door panels run on heavy duty double bogey wheels as standard. Quad rollers used for very heavy panels.
- For the ultimate finish the perimeter frame has snap-in flat fillers to close off all unwanted recesses. These fillers are isolated to prevent thermal transmission from inside to outside.
- The flat sill is ideal for recessing into the floor.
- This sliding door has been tested for compliance with the relevant Australian Standards and achieved a high water resistance of 300Pa, making the product suitable for most residential applications.

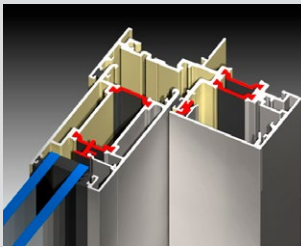

This illustration highlights the thermal break through the frame and on the flat filler. This frame is also available in a dual colour finish.

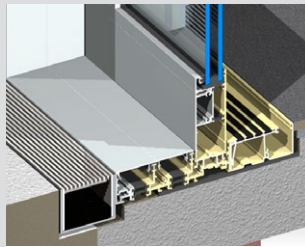

The door sill can be completely recessed into the floor as shown above. For the ultimate finish you can fit a recessed lineal drain on the outside and a retractable roller screen on the inside.

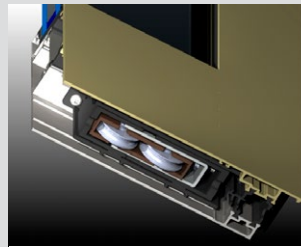

These heavy doors are supported on custom double bogey wheels that are designed to support panels up to 150kg. For very heavy panels up to 300kg quad rollers are used.

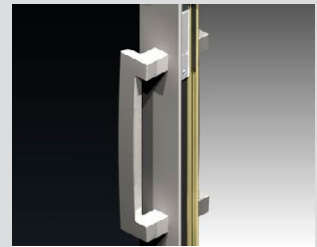

Mortice lock with bold ANDO™, MIRO™ or ICON™ pull handles and matching cylinder escutcheons, ICON™ shown above. On heavy doors we recommend D-Pulls as shown above.

GENERAL

Max Frame Height*
3000mm

Max Panel Width*
2000mm

Max Glass Thickness
32mm

Frame Depth
110mm (2 track), 163mm (3 track), 217mm (4 track)

ENERGY

UW Range
2.1-5.2

SHGC Range
0.15-0.60

WEATHER

Maximum Water
300 Pa.

ACOUSTICS

8.5 Vlam Hush/ 10 / 6.5mm Vlam Hush™
Rw 37 (-1,-3)

6mm Tgh/ 12 / 6.5mm Vlam Hush™
Rw 37 (-1,-4)



*Dimensions subject to individual site conditions.
BAL-40 compliance may limit glass options. Maximum glass size for BAL-40 products is 4.5m2.
vantagealuminium.com.au/731